



Portable Dance Pole User Manual



Read this user manual thoroughly before using the product.

Safety Instructions

1. Never use oil and/or lotion on your hands or body before using the dance pole. The oil and/or lotion transferred onto the pole will make it slippery and hard to hold, which might cause serious bodily injury.
2. The dance pole should not be installed under false or suspended ceilings that are not sturdy enough.
3. Never place a carpet under the dance pole as it could affect the stability of the product.
4. Before the installation, all shrink-wrap covering the parts must be removed. Please DO NOT use a sharp instrument/knife to do this, as damage may be caused.
5. Never apply any weight over weight capacity of the dance pole on this dance pole.
6. When carrying out the assembly, the dance pole is heavy and at full height, NOT easy to handle. It is, therefore, MANDATORY/COMPULSORY that two people install the dance pole i.e. 1 people should lift it into position and 1 person hold the pole while the other rotates/expands the height adjuster.
7. Please apply force to the dance pole from the side to ensure it doesn't slip out of place before using.
8. NEVER use your pole if you are in any doubt about its assembly, stability or how to use it.
9. Misusing a pole can be dangerous not only to you but also anyone close to the pole. The use of any pole is always at the user's discretion.
10. Pole Exercise is extremely physical and uses muscles that you will not have used before and therefore if you are not warmed up muscle damage and strains can occur.
11. Practice each basic move until you are happy with your ability to do the move before continuing on to the next one. If at any time you feel uncomfortable, your muscles hurt, or you are short of breath - take a break and try again later. It is better to rest between moves, let someone else try and then progress on to the next.
12. The dance pole may make noise when making spinning moves after long term use. It's recommended to lubricate the corresponding joints.

Switch between Spin/Static Modes

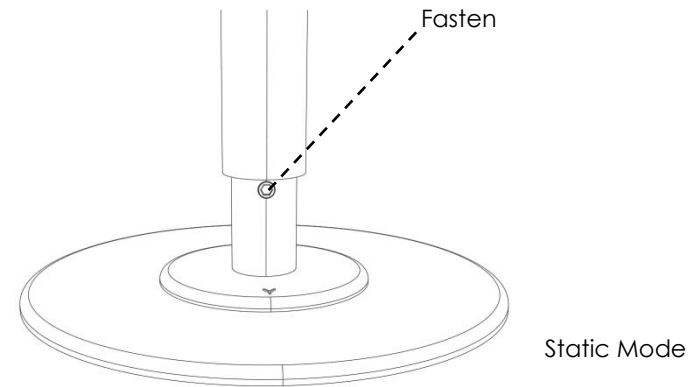

Fasten the screws nuts for static mode.

(Ensure one of the screw nuts aligns with the letter "Y" on the bottom base.)

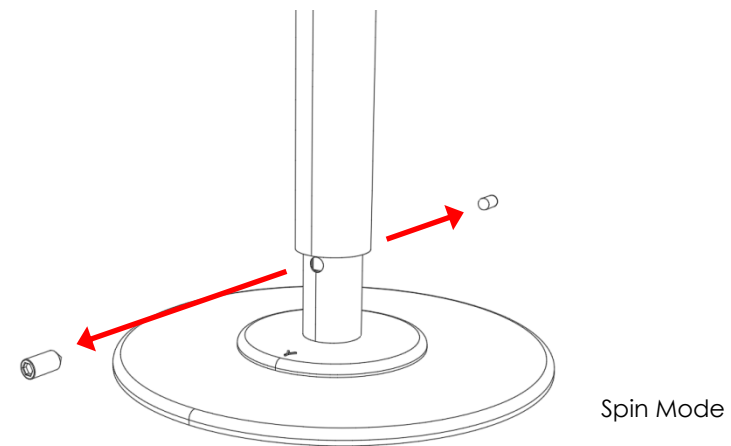

Loosen out both screw nuts for spin mode.

Note

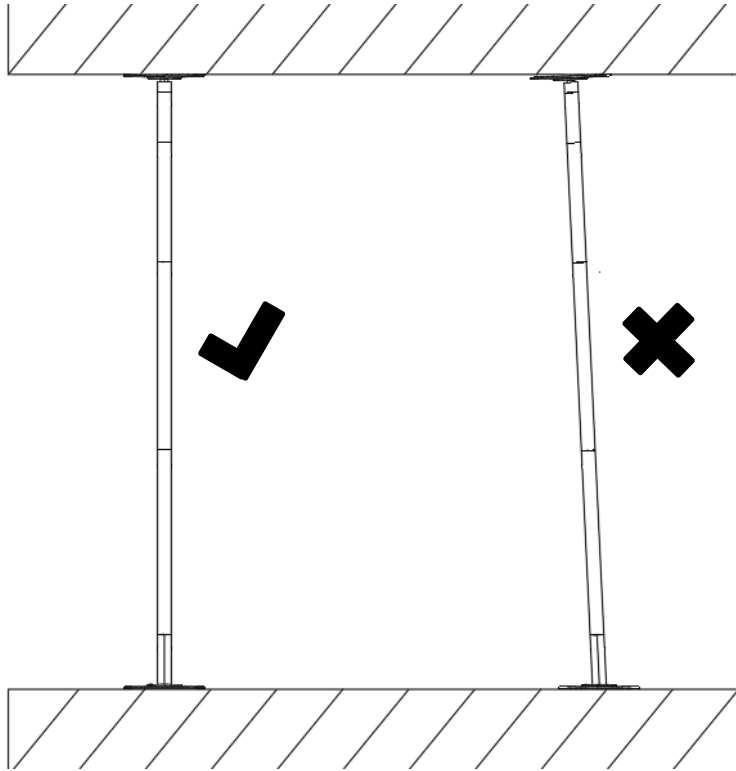

- Once the top base is against the ceiling and before it is tightened further, make sure that the pole is vertical.
- It is critical that the top base is flat against the ceiling. DO NOT expand the adjuster further until the top base is flat against the ceiling. If the top base is not flat, the plate could rotate, and slip or damage the ceiling.
- To ensure the security, it is **COMPULSORY** that two people install the Dance Pole i.e. 1 people should lift it into position and 1 person hold the pole while the other rotates/expands the height adjuster.
- Apply force to the dance pole from the side to ensure it doesn't slip out of place before using.

Specifications

Horizontal Weight Capacity	617 lbs (280kg)
Vertical Weight Capacity	1102 lbs (500kg)
Adjustable Height	7.3 ft to 9.3 ft (224 cm to 282 cm)

Package Contents

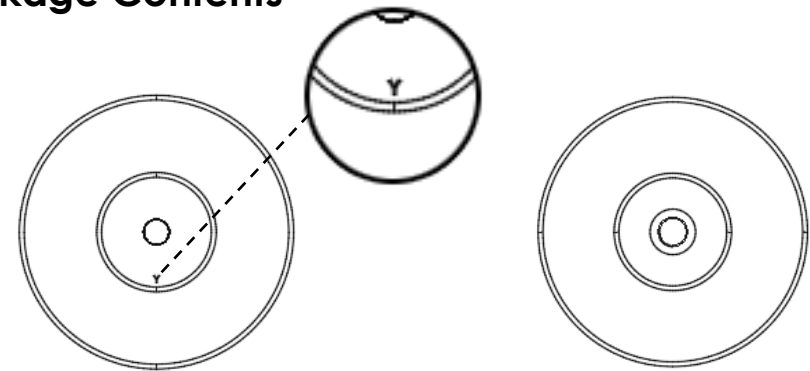

Bottom Base x 1

Top Base x 1



Bottom Pole x 1



Upper Pole x 1



Connecting Pole x 1



Cover x 1

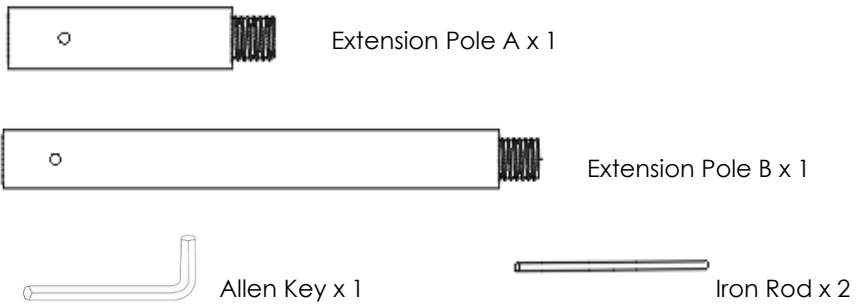

Choosing the Installation Location

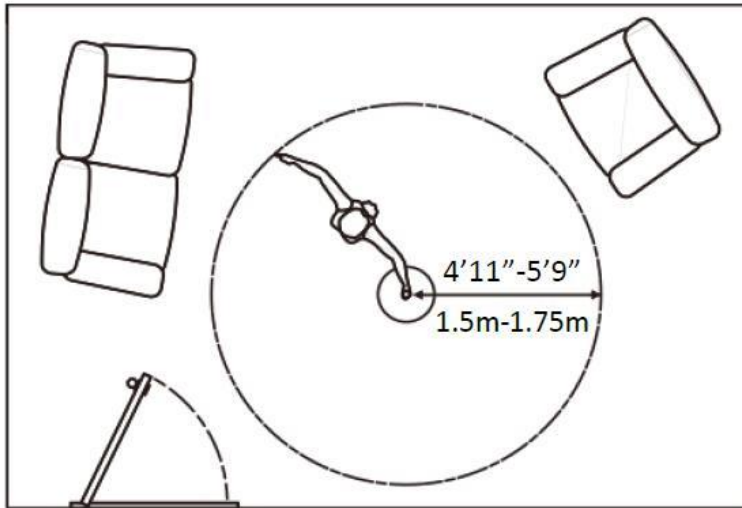

To use the pole properly you need to be able to rotate around the pole with your arms outstretched without hitting or touching anything whilst rotating.

Find the area by rotating around an imaginary pole with your arms outstretched, you can use a chair as an imaginary pole or, measure a circle with a diameter of approximately 9'10"-11'6" (3.0-3.5m).

This area will enable you to fully extend your arms. Maneuvers can be executed in a smaller space than the above but for beginners, the above space is recommended.

10

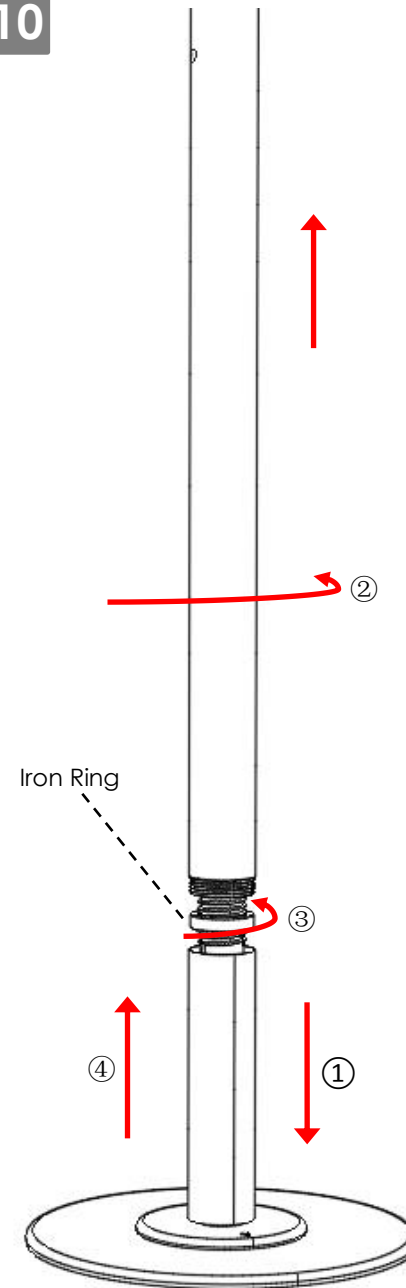

- ① Loosen the cover down.
- ② Rotate the bottom pole as shown to extend it until it could not go up further.
- ③ Rotate the iron ring upward until it could not go up further.
- ④ Secure the cover back to the bottom pole.

9

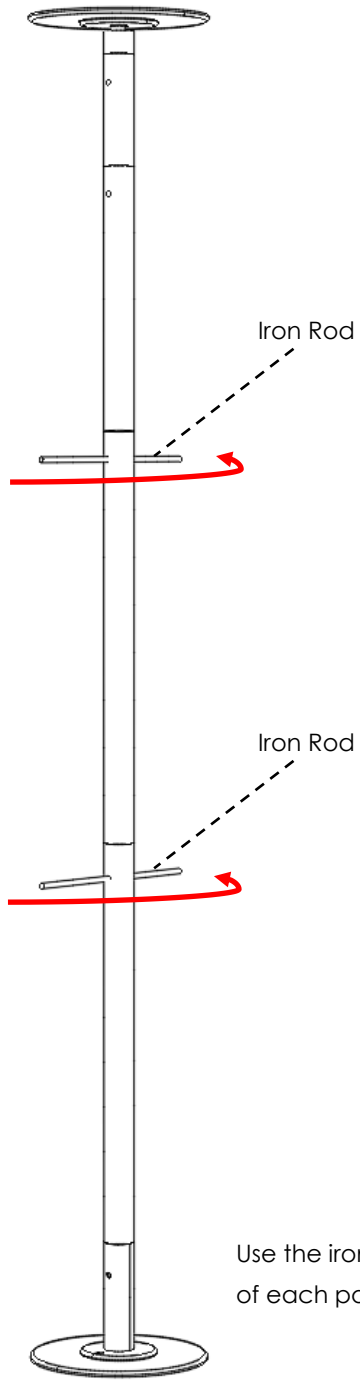

Use the iron rods to further secure the connection of each pole.

Assembly Instructions

1

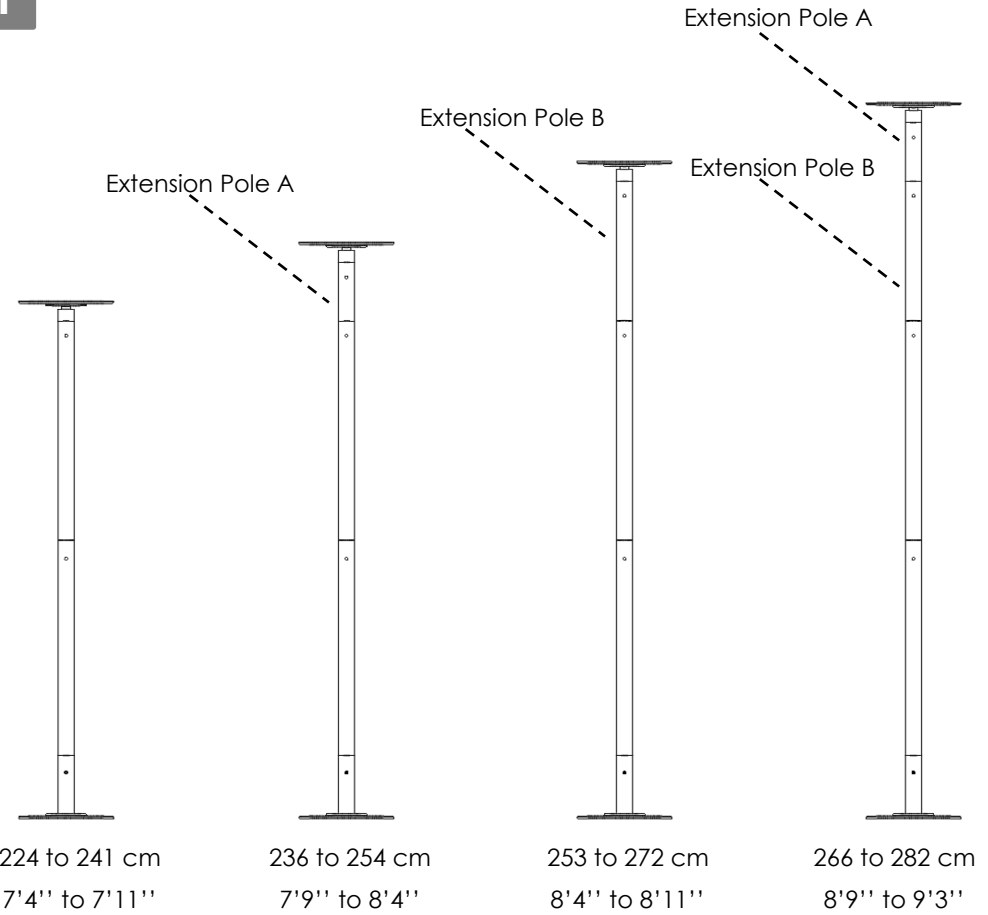

Measure the distance between your ground and ceiling and refer to the diagram below to decide if you need to install either the extension pole A or extension pole B or both of them, or none of them. In the following steps, we will take scenario of installing both extension poles as an example.

Note: Each scenario has overlap, please always increase the number of extension pole used if possible.

2

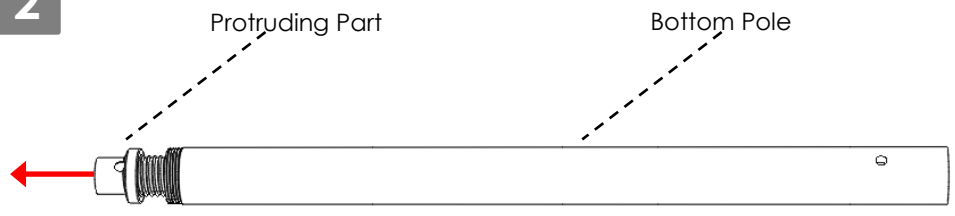

Loosen out the protruding part of the bottom pole a little bit as shown.

3

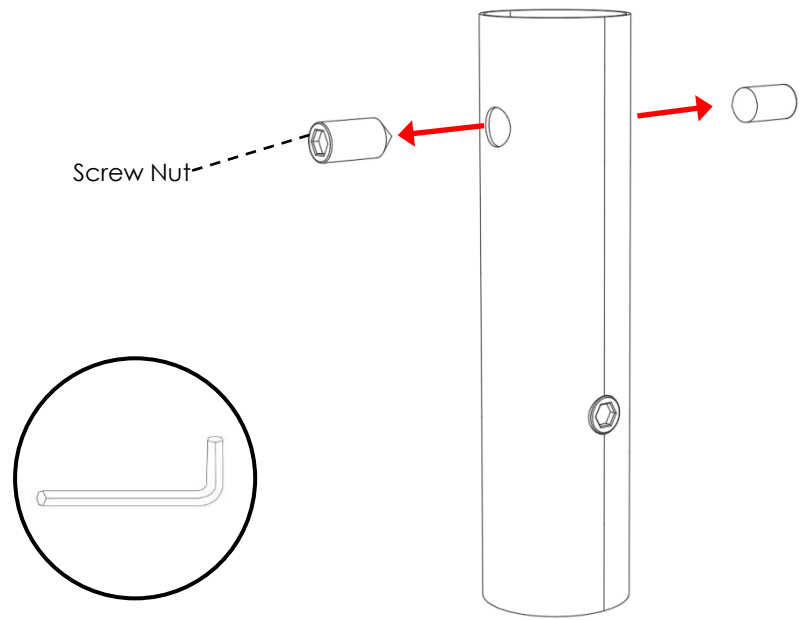

Use the allen key to loosen out the upper two screw nuts from the connecting pole.

8

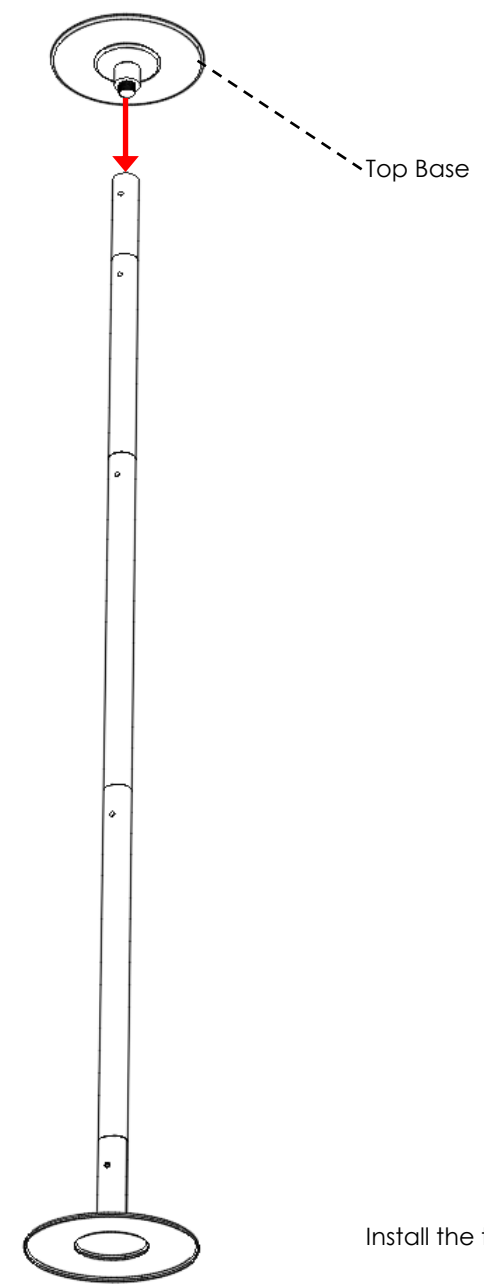

Install the top base as shown.

7

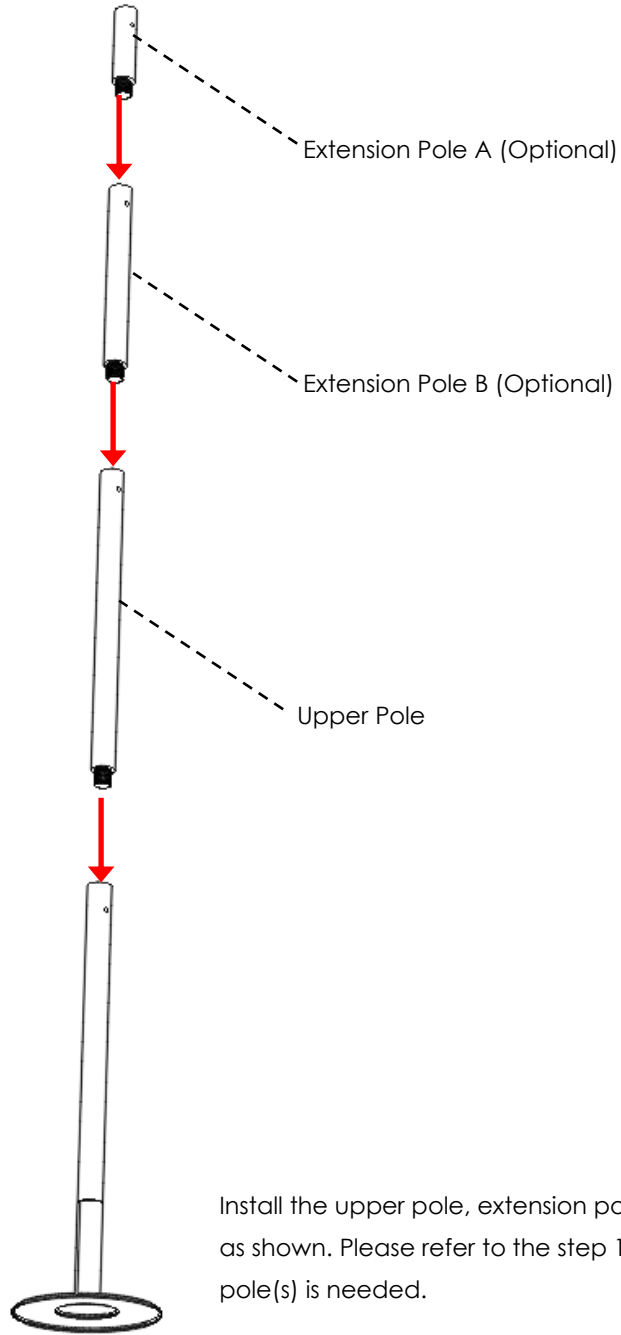

Install the upper pole, extension pole B, extension pole A as shown. Please refer to the step 1 on which extension pole(s) is needed.

4

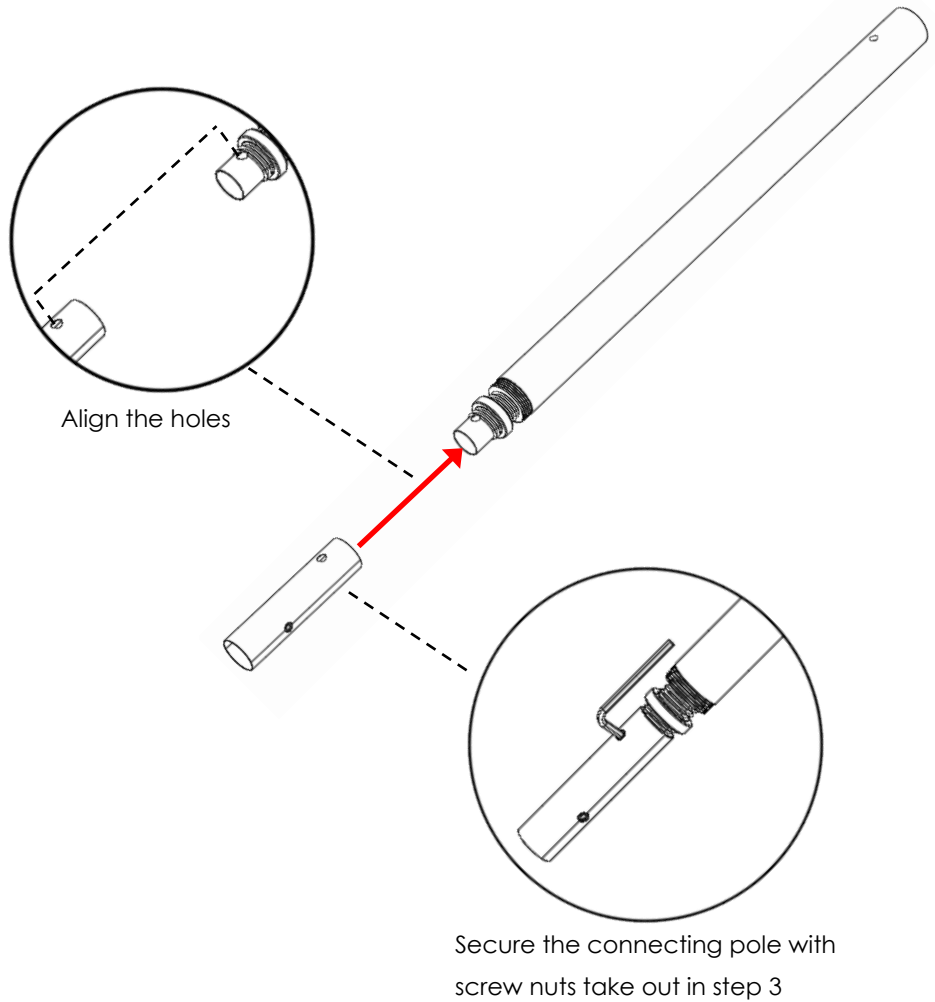

Install the connecting pole on the bottom pole as shown. (Align the holes). After that, secure the connecting pole with screw nuts taken out in step 3

5

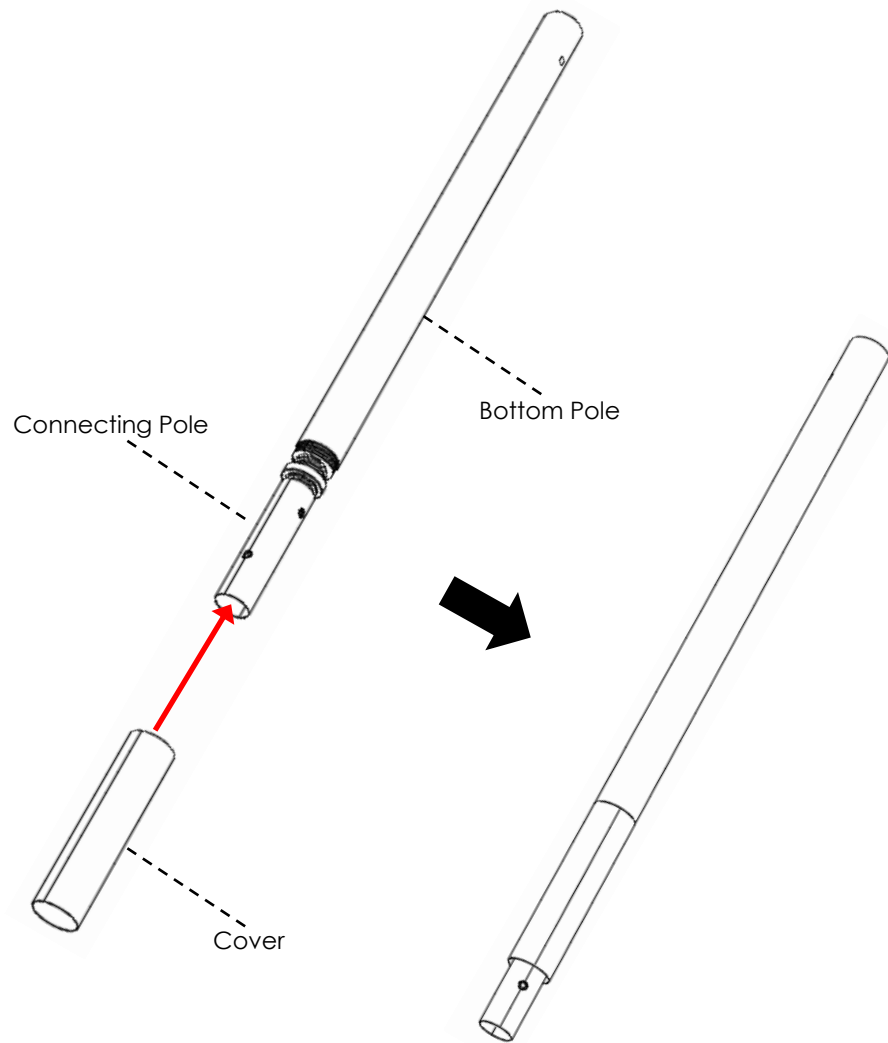

Thread the cover through the connecting pole and rotate it to secure it on the bottom pole.

6

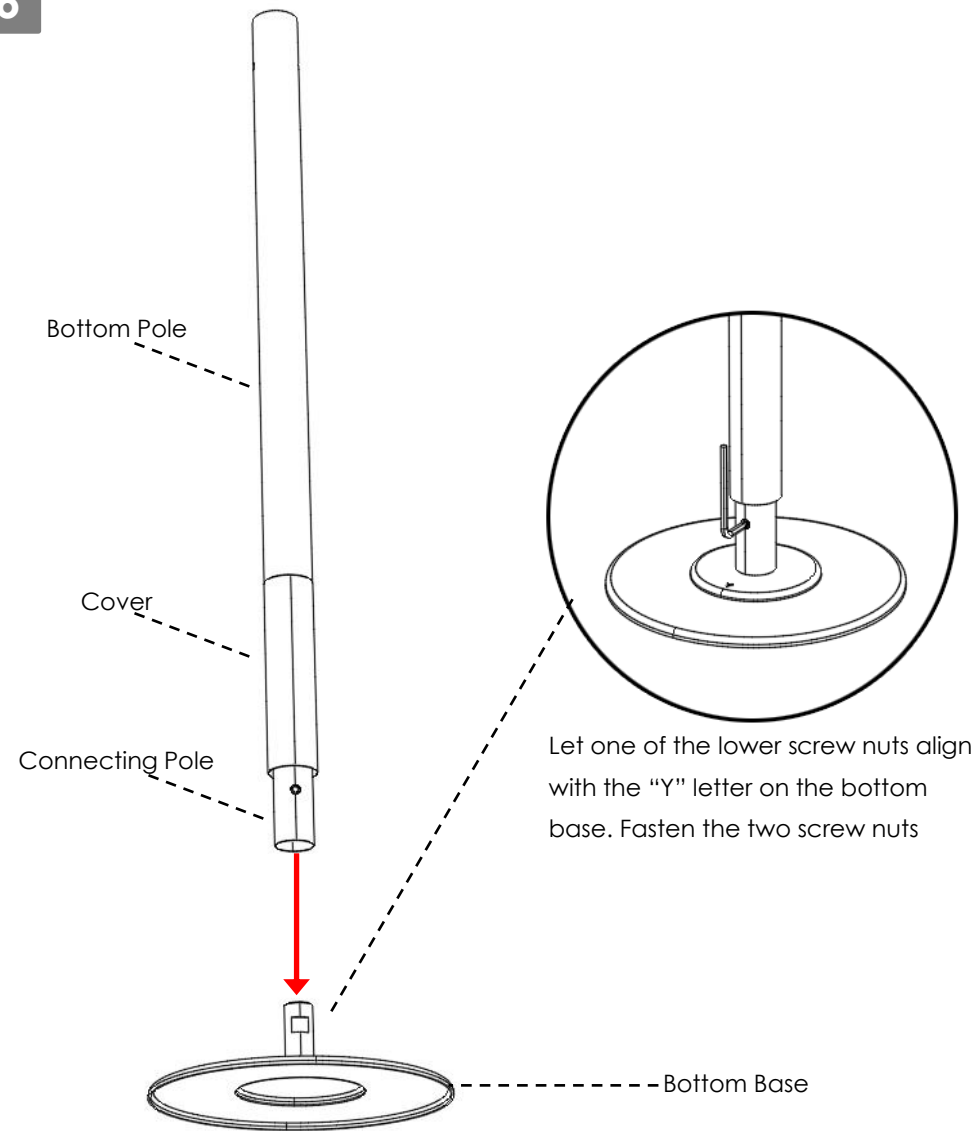

Let one of the lower screw nuts align with the "Y" letter on the bottom base. Fasten the two screw nuts

Connect the bottom base to the bottom of the connecting pole. Let one of the lower screw nuts align with the letter on the bottom base. After that, fasten the two screw nuts